



Print & Apply Labeller with Intelligent Motion™

# Videojet® 9550

The Videojet 9550 is a smarter print and apply labeller that targets zero unscheduled downtime and reduces costs and errors in case coding operations.

Operational downtime caused by label jams and routine manual adjustments is removed through Intelligent Motion Technology, which automatically and precisely controls the entire system. In addition, Direct Apply™ is a unique on-demand labelling method that allows accurate placement of the label onto the package without the need for an applicator – even at high speeds.

Maximise your line uptime, increase productivity and remove the risk of mislabelling packages with the most advanced and user friendly print and apply labelling system.

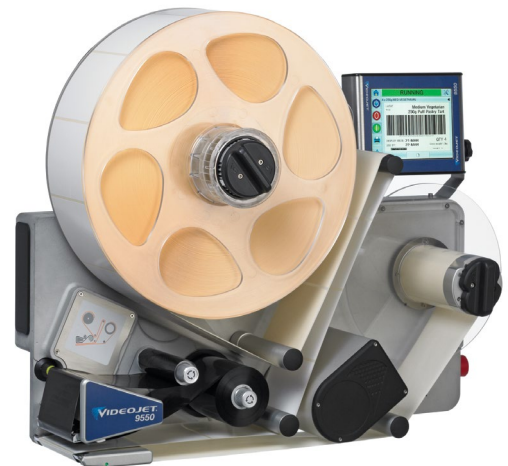

## Uptime Advantage

- Zero mechanical adjustments during day-to-day operation
- Optimises maintenance labour by eliminating more than 80% of wear parts
- Keep your lines running longer with automatic set-up

## Built-in productivity

- Never miss a label, regardless of line throughput and pack sizes with Direct Apply labelling up to 150ppm for a typical GS1 4"x6" label
- Optimise print quality and printhead life with automatic printhead pressure regulation
- Track performance and help achieve OEE improvements with on-screen diagnostics
- 53mm and 107mm printhead versions for optimum performance on a wide range of label sizes

## Code Assurance

- Virtually eliminate operator errors, helping to ensure products are coded correctly with built-in Code Assurance software features
- Minimise operator touches with on-board label database for accurate job selection
- Automate bar code creation by linking data from multiple text fields

## Simple usability

- Virtually eliminate label jams and simplify set-up with Direct Apply for mainstream top or side applications
- Minimise misapplied and snagged labels with on-demand Direct Apply using no plant air
- Perform label and ribbon changes in less than 60 seconds through simplest web path
- Quickly check status and select jobs with single, intuitive interface that makes operation easy

# Videojet® 9550

## Print & Apply Labeller with Intelligent Motion™

### Application method

Direct Apply (standard) with Intelligent Motion™ Label Drive  
Optional applicators: Front Apply, Ultra High Speed and Telescopic Tamp (see separate data sheet)

### Print technology

Thermal Transfer printing with Intelligent Motion™ Ribbon Drive and Direct Thermal 53mm and 107mm printhead versions

### Print resolution

300dpi / 200dpi emulation mode

### Printhead health monitoring

Tool-free quick release printhead replacement

### Print speed

1.6 – 19.7 inches/sec (40 – 500mm/sec)

### Throughput

Up to 350 packs per minute, dependent on line speed and pack size only

### Ribbon specification

Width: 2.2" (55mm), 3.0" (76mm) and 4.3" (110mm) (standard)

Capacity: Up to 830m, including automatic ribbon save (< 1mm ribbon gap between successive prints irrespective of label size or speed)

Low Ribbon and End of Ribbon detection with predicted changeover time built in as standard

### Label specification

Width/length: 2.0" to 4.5" / 2.0" to 11.8" (50 to 115mm / 50 to 300mm)

Capacity: Up to 400mm spool diameter (typically delivers over 9000 typical GS1 bar code labels per roll)

Low Labels and End of Label Reel detection, with predicted changeover time built in as standard

Automatic adjustment for label/backing type and label size

400MB on-board label database, sufficient for 25,000 typical GS1 bar code label designs

### Print capabilities

Full downloadable font support using TrueType® fonts (including multiple languages and Unicode support); fixed, variable and merged text fields; flexible date/time formats; flexible shift code formats; auto best before date calculations and concession management; calendar rules; auto incrementing/decrementing text, counters and bar codes; multiple graphic formats supported (up to maximum print area); link fields to databases; scalable text and text blocks

### Bar codes supported

EAN 8, EAN 13, UPC-A, UPC-E, Code 39, GS1-128, Code 128, ITF, RSS (including 2D composite codes); others available upon request

### Connectivity

Ethernet, Power-over-Ethernet, RS232, Configurable I/O (24V, PNP and volt free)

USB (for backup/restore and label upload), remote Control Videojet 9550 via a web browser

### Communications protocols

Compatible with Videojet Clarisuite™

Videojet binary and simple-ASCII protocols

Compatible with any label design software which supports Zebra or Sato print engines  
Zebra (ZPL), Sato (SBPL) and Markem-Imaje (Cimcomms) protocol support

### Interface

CLARITY™ Controller with Interactive on-board video tutorials

### Language capabilities

Arabic, Bulgarian, Czech, Danish, English, German, Greek, Finnish, French, Hebrew, Hungarian, Italian, Japanese, Korean, Dutch, Norwegian, Polish, Portuguese, Romanian, Russian, Serbian, simplified Chinese, Slovak, Spanish, Swedish, Thai, Turkish, Traditional Chinese, Vietnamese

### Air consumption

No air required for standard Direct Apply labelling

### Power consumption

90 – 260VAC (115W at 50 packs per minute)

### Operating environment

Temperature Range: 41-104°F (5-40°C)

Humidity: 20 - 85% Relative, non-condensing

### Weight

88.2lbs (40kg) (max, including ribbon and labels)

### Applicable certifications

CE, TUV

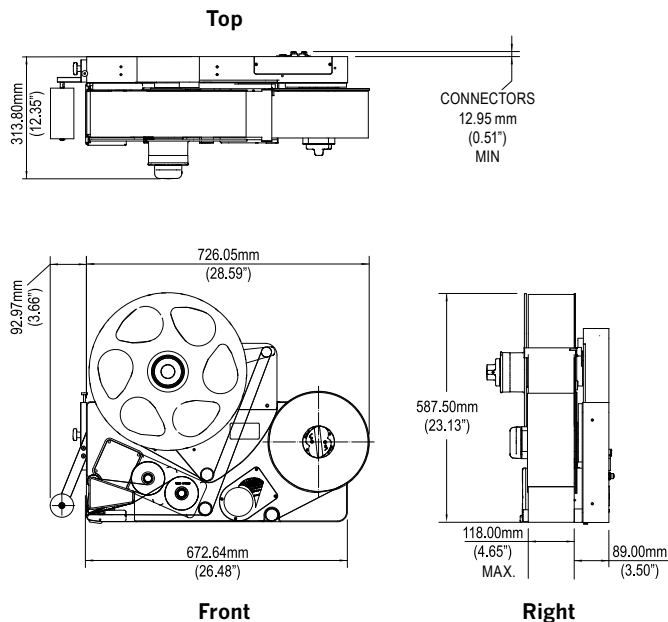

Call us free on **0800 500 3023**

Email **uksales@videojet.com**

or visit **www.videojet.co.uk**

Videojet Technologies Ltd.

4 & 5 Ermine Centre, Lancaster Way,

Huntingdon, Cambridgeshire PE29 6XX / UK

© 2016 Videojet Technologies Inc. — All rights reserved.

Videojet Technologies Inc.'s policy is one of continued product improvement. We reserve the right to alter design and/or specifications without notice. TrueType is a registered trademark of Apple Computer, Inc.

Part No. SL000591  
ss-9550-en-0916

