



Continuous Inkjet

Videojet® 1550

The 1550 delivers advanced features and tools to minimise downtime while providing high-quality printing.

When uptime and availability are critical and Overall Equipment Effectiveness (OEE) is your goal, the Videojet 1550 is for you. Its advanced features and tools help minimise planned and unplanned downtime and maximise printer availability.

The 1550 is ideal for daily and multi-shift applications with line speeds up to 914 feet per minute.



Uptime Advantage

- Dynamic Calibration™ keeps your print quality optimal in changing environmental conditions
- CleanFlow™ printhead technology reduces ink buildup and lets you run longer between printhead cleanings
- Long run time between preventive maintenance – 12,000 hour core life

Built-in productivity

- User interface not only shows the printer availability percentage, but also the data behind it
- Advanced drill down capability to trace downtime events to their root cause, so you can fix them
- Configurable settings let you track availability to match your production processes and OEE methods
- Recover faster with CLARITY's one touch fault information

Code Assurance

- Prevent costly coding mistakes with CLARITY-based user interface
- Foolproof set-up wizards make it easy to get codes right and hard to get them wrong
- Further reduce errors by pulling data directly from database systems

Simple usability

- Large, responsive 10.4" touchscreen is easy to operate and visible from a distance
- Smart Cartridge™ fluid system significantly reduces waste, mess and mistakes
- Automatic start-up and shutdown

Videojet® 1550

Continuous Inkjet

Line speed capability

Can print 1 to 5 lines of print at speeds of up to 914 ft./min. (278.6 m/min.) (10 characters per inch, single line of print)

Font matrix configuration

Single-line: 5x5, 5x7, 7x9, 8x12, 11x16, 17x24, 34x34
Twin-line: 5x5, 5x7, 7x9, 8x12, 11x16
Tri-line: 5x5, 5x7, 7x9
Quad-line: 5x5, 5x7
Five-line: 5x5

Linear bar codes*

UPC A&E; EAN 8 & 13; Code 128 A, B & C;
UCC/EAN 128; Code 39; Code 93; Interleaved 2 of 5

DataMatrix codes*

10x10, 12x12, 14x14, 16x16, 18x18, 20x20, 24x24, 34x34

Nominal character height

Selectable from 0.079" (2mm) to 0.40" (10mm), depending on font

Throw distance

Optimal: 0.472" (12mm)
Range: 0.197" (5mm) to 0.591" (15mm)

User interface

10.4" high-response TFT-LCD touch screen
WYSIWYG touch to edit message editing

Custom logo/graphics

Can be created via optional CLARISOFT® software

Character sets

Chinese, Russian/Bulgarian, Turkish/Scandinavian, Greek, Arabic,
Japanese/Kanji, Hebrew, Korean, East European and European/American

Languages and interface options

English, Arabic, Bulgarian, Czech, Danish, Dutch, Finnish, French,
German, Greek, Hebrew, Hungarian, Italian, Japanese, Korean,
Norwegian, Polish, Portuguese, Russian, Simple Chinese, Spanish,
Swedish, Thai, Traditional Chinese, Turkish and Vietnamese

Data interface

Ethernet (standard)
Clarisoft/Clarinet® via ethernet
Message management via USB

Message storage

More than 250 complex messages

Environmental protection

IP55 (IP65 option, no plant air required); stainless steel cabinet

Printhead

Heated printhead
Positive air (standard)
Diameter: 1.63" (41.3mm)
Length: 10.62" (269.8mm)

Printhead umbilical

Ultra flexible
Length: 9.84' (3m) optional 19.69' (6m)
Diameter: 0.91" (23mm)
Bend radius: 4.0" (101.6mm)

Make-up fluid consumption

As low as 2.4ml per hour

Fluids containers

Ink Smart Cartridge™ 0.793 qt. (750ml)
Make-up Smart Cartridge 0.793 qt. (750ml)

Temperature/humidity range

32°F to 122°F (0°C to 50°C)
0% to 90% RH non-condensing
With selected inks; actual installation may require additional hardware based on production environment conditions

Electrical requirements

Nominal supply power 100-120 / 200-240 VAC at 50/60 Hz, 120 W

Approximate weight

Unpacked and dry: 48.5lbs. (22kg)

Options

IP65 with 316 stainless steel (no plant air required)
Dry air kit for high humidity (requires plant air)
60 or 70 micron nozzle
Food grade version
90 degree printhead
Wide range of accessories

* CLARISOFT Package Coding Design software required for bar codes and other advanced functionality.

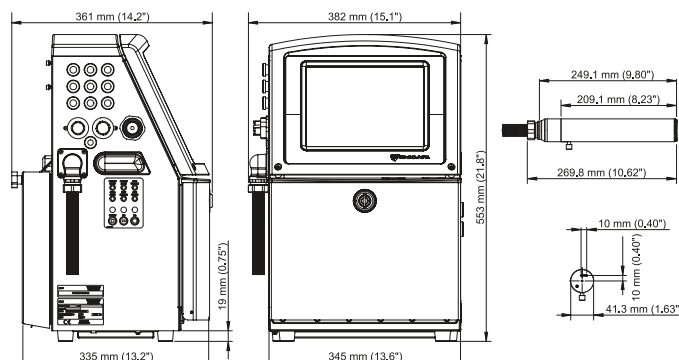

Call us free on **0800 500 3023**

Email **uksales@videojet.com**

or visit **www.videojet.co.uk**

Videojet Technologies Ltd.

4 & 5 Ermine Centre, Huntingdon, Cambridgeshire PE29 6XX / UK

Call us free on **+353 1 450 2833**

Email **irelandsales@videojet.com**

or visit **www.videojet.ie**

Videojet Ireland

C2, South City Business Park, Tallaght, Dublin 24 / Ireland

© 2019 Videojet Technologies Inc. — All rights reserved.

Videojet Technologies Inc.'s policy is one of continued product improvement. We reserve the right to alter design and/or specifications without notice.

Part No. SL000523
ss-1550-en-0919

