



Continuous Inkjet

Videojet® 1860

The Videojet 1860 provides advanced warning of clogging and EHT trips. The SIMPLiCiTY™ interface greatly reduces operator interactions, and the optional VideojetConnect™ Remote Service minimizes the need for on-site service calls.

In a world where setting higher standards is a constant reality, production line equipment needs to be more intelligent to help enable even higher line performance. The Videojet 1860 Continuous Inkjet printer helps your team reset the bar for performance. Predictive capabilities provide up to 8 hours advanced notification of the most common downtime generating faults under normal operating conditions. With the SIMPLiCiTY™ interface, operating the 1860 will become second nature for your team. And with optional VideojetConnect™ Remote Service, your team can access Videojet experts to help improve productivity and troubleshoot potential issues in ways that other printers can't.



Performance without surprises

- Predictive capabilities provide up to 8 hours advanced notification of the most common downtime generating faults under normal operating conditions
- An industry-first ink build-up sensor provides advance warning of clogging and EHT trips
- Recover in minutes from unplanned interruptions with optional VideojetConnect™ Remote Service - minimizing the need for on-site service calls

Minimal touch design

- Significantly reduce operator error through advanced Code Assurance
- Access guided, embedded video instruction for routine printer tasks
- Complete your preventive maintenance with 3 easy-to-replace SmartCell™ components
- Access technical experts at the touch of a button through optional VideojetConnect™ Remote Service

Natural fit in your line

- Lower your cost of operation with up to 20% more efficient solvent usage*
- Hygienic design following industry guidelines
- Innovative printhead design improves speed by up to 20% in certain applications
- Integrate with factory systems using standard industry protocols with optional workflow modules
- Optional 90 degree printhead has the ability to ratchet through 350 degrees for optimal integration with the production line

Built-in evolution

- Do more in the future by upgrading your printer with optional workflow modules
- Reduce unplanned downtime by accessing updates to predictive capabilities
- Operate more effectively with detailed runtime analytics and reporting, partnering with Videojet Service to get better over time

*Compared to existing 1000 Line models

Videojet® 1860

Continuous Inkjet

Line speed capability

Can print 1 to 5 lines of print at speeds of up to 960fpm (293mpm)
(10 characters per inch, single line of print)

Font matrix configuration

Single-line: 5x5, 4x7, 5x7, 7x9, 9x12, 10x16, 16x24, 25x34
Twin-line: 5x5, 4x7, 5x7, 7x9, 9x12, 10x16
Tri-line: 5x5, 4x7, 5x7, 7x9
Quad-line: 5x5, 4x7, 5x7
Five-line: 5x5

Linear bar codes

UPC A&E; EAN 8 & 13; Code 128 A, B & C; UCC/EAN 128;
Code 39; Interleaved 2 of 5; GS1

DataMatrix codes

10x10, 12x12, 14x14, 16x16, 8x18, 18x18, 20x20, 22x22, 24x24, 26x26, 8x32,
32x32, 12x36, 16x36, 16x48

QR codes

21x21, 25x25, 29x29, 33x33
Error correction mode L, M, Q or H

Nominal character height

Selectable from 0.079" (2mm) to 0.40" (10mm), depending on font

Throw distance

Optimal: 0.472" (12mm)
Range: 0.079" (2mm) to 0.787" (20mm)

User interface

10.4" high-response TFT-LCD touch screen
WYSIWYG touch to edit message editing

Custom logo/graphics

Can be created via optional CLARISOFT™ software*

Character sets

Chinese, Russian/Bulgarian, Turkish/Scandinavian, Greek, Arabic, Japanese/Kanji,
Hebrew, Korean, Thai, East European and European/American

Languages and interface options

English, Arabic, Bulgarian, Czech, Danish, Dutch, Finnish, French, German, Greek,
Hebrew, Hungarian, Italian, Japanese, Korean, Norwegian, Polish, Portuguese (BR),
Romanian, Russian, Serbian, Simplified Chinese, Spanish, Swedish, Thai,
Traditional Chinese, Turkish and Vietnamese

Input/output

Product detect input; Encoder input; Beacon (Alarm light) output; RS232 (requires RS232
connector kit); Relay output (2x); USB 2.0 (2x); Ethernet LAN

Message storage

More than 250 complex messages

Environmental protection

IP55, no plant air required, stainless steel cabinet or
IP66, no plant air required, 316 stainless steel cabinet

* CLARISOFT™ Package Coding Design software required for bar codes and other
advanced functionality.

Printhead

Heated, 45 degree slanted printhead
Clean Flow™ technology
Diameter: 1.6" (41.3mm)
Length: 9.5" (240.6mm)

Printhead umbilical

Ultra flexible
Length: 9.84' (3m) optional 19.69' (6m)
Diameter: 0.67" (17mm)
Bend radius: 4.0" (101.6mm)

Make-up fluid consumption

4.5ml per hour (MEK at 20°C)

Fluids containers

Ink and Make-up Smart Cartridge™ 1.06 qt (1000ml)

Temperature/humidity range

32°F to 122°F (0°C to 50°C)

10% to 90% RH non-condensing

*With selected inks; actual installation may require additional hardware
based on production environment conditions*

Electrical requirements

Nominal supply power 100-240 VAC at 50/60Hz, 70W

Approximate weight

Unpacked and dry: 48.5lbs. (22kg)

Options

60 or 70 micron nozzle
Dry air kit for high humidity (requires plant air)
Advanced input/output
SIMPLICITY™ Workflow Modules: Ethernet/IP™ or PROFINET, Scan2Run™,
High Speed Imaging
Wide range of accessories
90 degree printhead

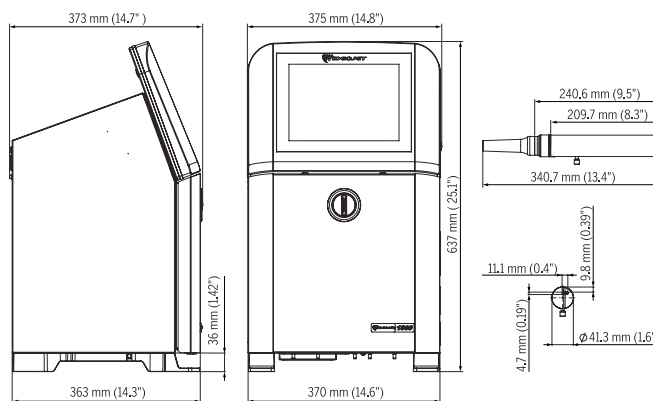

Dimensions shown are for the IP66 model



Call (65) 6444 4218

Email marketing.singapore@videojet.com

or visit www.videojet.sg

Videojet Technologies (S) Pte Ltd
No. 11 Lorong 3 Toa Payoh
Block B #03-20/21 Jackson Square
Singapore 319579

© 2020 Videojet Technologies Inc. — All rights reserved.

Videojet Technologies Inc.'s policy is one of continued product improvement.
We reserve the right to alter design and/or specifications without notice.

Part No. SL000641
ss-1860-en-sg-0120

