



Laser Marking System

Videojet® 7810 UV Laser

Our UV laser delivers high-resolution, permanent codes enabling product lifetime track and trace security for pharmaceutical and medical manufacturers.

Packaging operations that require high-quality, traceable codes for camera readability can rely on the Videojet UV laser to help meet regulatory coding requirements. Direct marking of permanent codes helps prevent the risk of counterfeiting or manipulation to your product identification.

The 7810 applies crisp 2D, alphanumeric and other typical codes and meets GS1, securPharm, HIBCC, and ICCBBA code standards. The UV laser is particularly well suited to polyethylene fibers such as DuPont™ Tyvek® and commonly used, rigid plastic materials such as white HDPE and LDPE. Videojet 360° Arc Compensation Software helps ensure the same mark quality can be achieved on rotational devices as well as straight line applications.



For the installation and startup of the 7810 system, Videojet offers process validation in accordance with GAMP® 5 standards

Uptime Advantage

- Zero consumables to replace during day-to-day operation keeps lines running longer
- Maximum printer availability with air-cooled laser source that virtually eliminates unscheduled downtime
- No daily mechanical maintenance procedures help increase uptime

Built-in productivity

- High throughput on both rotary and linear applications up to 250 products per minute
- UV wavelength enables high speed marking-on-the-fly of HDPE/LDPE packaging to increase efficiency
- Mark quality, vision readable 2D codes up to (5.0 m/sec.)

Code Assurance

- Permanent codes help ensure complete product lifetime traceability and anti-counterfeiting
- Videojet 360° Arc Compensation Software feature enables consistent high-quality marks on rotational devices virtually eliminating distortion
- Repeatable high contrast color change for top grade vision readability on white HDPE/LDPE packaging

Simple usability

- Coding processes are simplified through the ability to mark any code, in any orientation, anywhere on the product
- UV wavelength marks high resolution and high contrast onto HDPE/LDPE without the need for additives and revalidation of packaging materials

Videojet® 7810

UV Laser Marking System

Marking fields

64x76 mm² (SS10, f=103 mm) - 375x375 (SS07/SS10, f=511 mm)

Marking heads

SS10 and SS7 with focusing lenses: f=103 mm/160 mm/214 mm/511 mm

Marking speed

Up to 500 characters per second; 984 ft/min (300 m/min)

Laser source

Pulsed Nd: YVO₄ (Vanadat)
Power class 2-Watt
Central emission wavelength: 355nm

Beam deflection

2 high-speed galvanometer scanners

Beam orientation

90-degree

Operator interface

Smart Graph software on PC; configurable in 12 languages

Language capabilities

Chinese, Czech, Dutch, English US, French, German, Italian, Japanese, Polish, Portuguese, Russian, and Spanish

Communication

Ethernet, TCP/IP and RS232, digital I/Os
Inputs for encoders and product detector triggers
I/Os for start, stop, external error, job select, trigger, trigger enable, encoder; system ready, ready to mark, marking, shutter closed, error, bad, good signals and machine/operator interlocks

Integration

Direct integration into complex production lines via scripting interface
Integration via Ethernet and RS232 interface
Highly precise side guided height adjustment via mounting with T-nut baseplate

Electrical requirements

100-240 VAC (autorange), 50/60 Hz

Power consumption

Typically 400Watt, 10A

Cooling system

Air cooled

Environment

50 - 104° F (10-40°C) (non-condensing)

Sealing and safety standards

Marking unit: IP20
Supply unit: IP21
LASER CLASS 4 product (acc. to IEC / EN 60825-1:2007)

Approximate weight

Supply unit: 44 lbs. (20 kg)
Marking unit: 55 lbs. (25 kg) max, without F-Theta lens

Applicable certifications

CE, CB, TÜV/NRTL

Marking unit dimensions

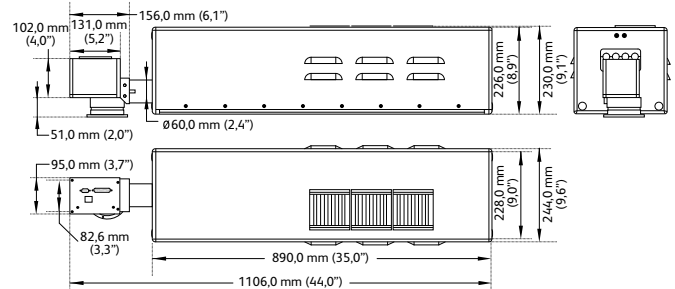

Supply cabinet dimensions

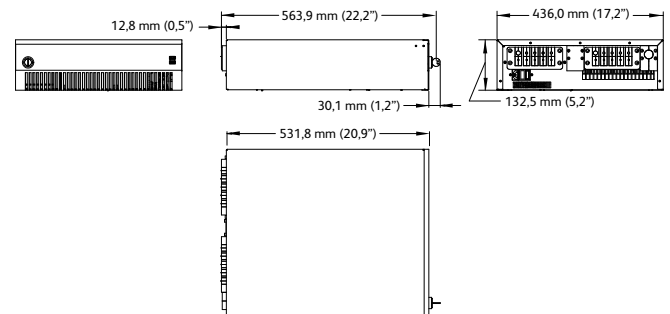

Call **800-843-3610**

Email **info@videojet.com**

or visit **www.videojet.com**

Videojet Technologies Inc.

1500 Mittel Blvd. Wood Dale IL 60191 / USA

©2016 Videojet Technologies Inc. — All rights reserved.

Videojet Technologies Inc.'s policy is one of continued product improvement.

We reserve the right to alter design and/or specifications without notice. Windows is a registered trademark of Microsoft Corporation. DuPont is a trademark and Tyvek is a registered trademarks of E. I. du Pont de Nemours and Company.

VIDEOJET
PHARMA LINE