



Laser Marking System

Videojet® 7510

The 7510 50-Watt fiber laser provides high quality marking and machine-readable codes at ultra-fast line speeds.

Small in size yet powerful in performance, the 7510 enables manufacturers to mark crisp, clear codes at up to 440 m/min to meet demands for increased throughput and more code content.

The 50-Watt fiber laser is specifically engineered for high speed serialization coding of substrates such as HDP, nylon, PVC, as well as aluminum and stainless steel. It goes without saying that the 7510 meets the code standards of GS1, securPharm, HIBCC, and ICCBBA.

In addition, Videojet offers process validation in accordance with GAMP® 5 standards for the installation and startup of the 7510 system.



Uptime Advantage

- Maximum performance and laser source life expectancy up to 100,000 hours (mean time before failure)
- Air-cooled laser source virtually eliminates maintenance intervals
- No wear parts minimizes downtime
- 90% more energy efficient compared to predecessor 100W Nd:YAG laser system

Built-in productivity

- Optimized to mark-on-the-fly at line speeds up to 440 m/min
- Large marking window provides more time to mark, increasing throughput and maximizing productivity
- On-screen diagnostics track causes of downtime and help troubleshooting to get the line back up and running quickly*

Code Assurance

- Optional CLARiTY® Laser Controller offers built-in software features that help reduce operator errors and help ensure products are coded correctly
- High precision scan head delivers consistent high quality codes across the entire mark window
- Permanent codes help assure product traceability and tamper-proofing

Simple usability

- Compact mechanical design with two beam delivery options simplify integration
- Intuitive color touchscreen interface option makes training and usability quick and easy

* With optional CLARiTY® Laser Controller

Videojet® 7510

Laser Marking System

Marking fields

Focal Length	100	163	254	420
Max. height/mm	113.7	181.9	283.1	498.5
Max. width/mm	87.3	142.2	221.7	366.5

Marking formats

Standard fonts (Windows® TrueType®/ TTF; PostScript®/ PFA, PFB; Open Type®/ OTF) and individual fonts, such as high-speed or OCR
 Machine readable codes: ID-MATRIX (ECC100, 140, 200: 10x10 for square formats, 8x8 to 16x48 for non-square formats; ECC plain; QR code); BAR CODES (BC25/25i/39/39E/93/128; GS1-128; UPC_A; RSS14TR/ST/STC; RS LIM/EXP) Graphics/ graphic components, logos, symbols, etc. (dxf, jpg, ai, etc.)
 Linear, circular, angular text marking; rotation, reflection, expansion, compression of marking contents
 Sequence and serial numbering; Automatic date, layer and time coding, real-time clock; Online coding of individual data (weight, contents, etc.)

Laser source

Ytterbium (Yb) pulsed fiber laser
 Power class 50-Watt
 Central emission wavelength: 1064nm (min: 1055nm, max: 1075nm)

Beam deflection

2 high-speed galvanometer scanners

Beam orientation

90-degree (standard) and straight-out (option)

Focusing (precision optics)

Focal lengths: f=100/163/254/420mm

Multiple operator interface options

Smart Graph software on PC; configurable in 12 languages (option)
 CLARiTY Laser Controller

Language capabilities*

Arabic, Bulgarian, Czech, Danish, English, German, Greek, Finnish, French, Hebrew, Hungarian, Italian, Japanese, Korean, Dutch, Norwegian, Polish, Portuguese, Romanian, Russian, Serbian, Simplified Chinese, Slovak, Spanish, Swedish, Thai, Traditional Chinese, Turkish, Vietnamese; interface dependent

Communication

Ethernet, TCP/IP and RS232, digital I/Os
 Inputs for encoders and product detector triggers
 I/Os for start, stop, external error, job select, trigger, trigger enable, encoder; system ready, ready to mark, marking, shutter closed, error, bad, good signals and machine/ operator interlocks

* With optional CLARiTY® Laser Controller

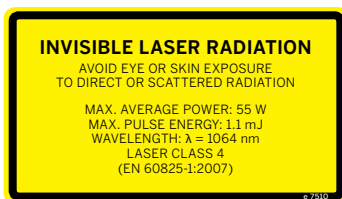

Integration

Direct integration into complex production lines via scripting interface
 Integration via Ethernet and RS232 interface
 Highly precise side guided height adjustment via dovetail joint

Electrical requirements

100-240 VAC (autorange), 600 VA, 1 PH, 50/ 60 Hz

Cooling system

Air cooled

Temperature/Humidity Range

15 - 35°C (59 - 95°F) and up to 40°C (104°F) with a duty cycle of 70%;
 10 - 90%, non-condensing

Sealing and safety standards

Marking unit: IP54
 Supply unit: IP21
 LASER CLASS 4 product (acc. to EN 60825-1:2007)

Approximate weight

Supply unit: approx. 20kg (44lbs.)
 Marking unit: approx. 5kg (11lbs.)

Applicable certifications

CE, TÜV/NRTL, FCC

Marking unit dimensions

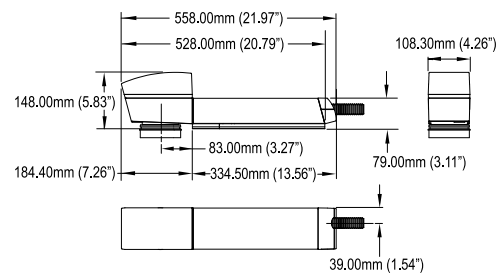

Supply cabinet dimensions

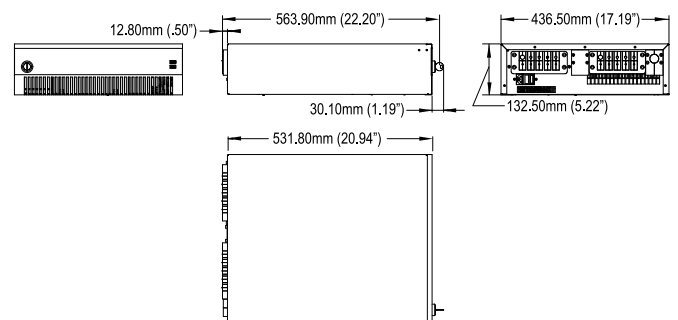

Call **800-843-3610**

Email **info@videojet.com**

or visit **www.videojet.com**

Videojet Technologies Inc.

1500 Mittel Blvd. Wood Dale IL 60191 / USA

©2016 Videojet Technologies Inc. — All rights reserved.

Videojet Technologies Inc.'s policy is one of continued product improvement. We reserve the right to alter design and/or specifications without notice. Windows and OpenType are registered trademarks of Microsoft Corporation. TrueType is a registered trademark of Apple Inc., registered in the united states and other countries. PostScript is a registered trademark of Adobe Systems Inc.

