



Print & Apply Labeller with Intelligent Motion™

Videojet® 9560 with Tamp Applicator

The Videojet 9560 with Tamp Applicator is a smarter print and apply labeller that targets zero unscheduled downtime and reduces costs and errors in case coding operations.

Intelligent Motion™ Technology automatically and precisely controls the entire system, helping to remove operational downtime often caused by label jams and snapped labels. A robust and simply designed applicator makes it easy to use, plus an integrated pack detect feature helps ensure accurate label placement.

The 9560 with Tamp Applicator is ideal for top-of-pack labelling onto variable height cases, bundles or shrink wrapped products, or for applications when the pack is stationary at the point of labelling.

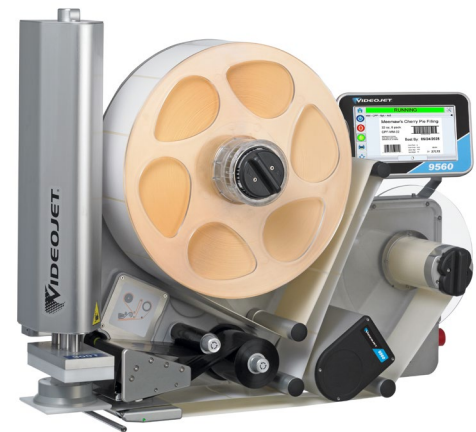

Industry-proven labelling technology

- Optimise maintenance labour by removing common wear and adjustment parts
- Built-in pack/case detect sensor eliminates the need for additional components, simplifying integration and set-up
- Clean, robust design helps protect components during operation
- Eliminate label jams for common top or side labelling applications

Remove end-of-line inefficiencies

- Intelligent Motion™ technology delivers automatic control of the system and eliminates the added parts and adjustments that can make other labelling machines fail
- A direct drive controls label speed and position without clutches, rollers or adjustments
- Electronic supply reel automatically adjusts and maintains tension irrespective of speed and label size

Seamless connectivity and compatibility

- Virtually eliminate operator errors, helping to ensure products are coded correctly with built-in Code Assurance software features
- Includes embedded Wi-Fi for secure remote access and analytical capabilities
- Intelligent emulation capabilities include EtherNet/IP™, PROFINET®, Zebra, SATO and CoLOS protocols

Simple usability

- Perform label and ribbon changes in less than 60 seconds
- Single simple 8-inch user interface for easy control
- Onboard support videos guide the operator through routine tasks
- Flexibility to position user interface remotely
- Ability to access the interface on a connected network, including via mobile devices

Videojet® 9560 with Tamp Applicator

Print & Apply Labeller with Intelligent Motion™

Application method

Pneumatic telescopic tamp module with automatic pack/case detection pad head
Stroke/Reach 11.8" (300mm) standard; optional Stroke/Reach 19.6" (500mm)

Print technology

Thermal Transfer printing with Intelligent Motion™ Ribbon Drive and Direct Thermal
53mm, 76mm and 107mm printhead versions

Print resolution

300dpi / 200dpi emulation mode

Printhead health monitoring

Tool-free quick release printhead replacement

Print speed

1.6 – 19.7inches/sec (40 – 500mm/sec) in one-inch increments

Throughput

Up to 60 packs per minute (depending on label size, telescopic stroke)
Recommended max. conveyor speed 98.4ft/min (30m/min)

Ribbon specification

Width: 2.2" (55mm), 3.0" (76mm) and 6.0" (160mm) standard
Capacity: Up to 830m, including automatic ribbon save; 500m with 160mm unit only
Low Ribbon and End of Ribbon detection with predicted changeover time built in as standard

Label specification

Label Width 2.0" to 4.5" (50mm to 115mm); dependent on printhead version
Label Length 2.0" to 5.9" (50mm to 150mm)
Capacity: Up to 400mm spool diameter
Automatic adjustment for label/backing type and label size

Tamp sizes

160mm x 160mm (standard on 160mm model)
160mm x 203mm (optional accessory only on 160mm units)

Tamp arm

500mm (19.7inch) reach

Print capabilities

Full downloadable font support using TrueType® fonts (including multiple languages and Unicode support); fixed, variable and merged text fields; flexible date/time formats; flexible shift code formats; auto best before date calculations and concession management; calendar rules; auto incrementing/decrementing text, counters and bar codes; multiple graphic formats supported (up to maximum print area); link fields to databases; scalable text and text blocks; 1GB on-board label database, sufficient for 62,000 typical GS1 bar code label designs

Bar codes supported

EAN 8, EAN 13, UPC-A, UPC-E, Code 39, GS1-128, Code 128, ITF, RSS (including 2D composite codes); others available upon request

Connectivity

Ethernet, Power-over-Ethernet, RS232, Configurable I/O (24V, PNP and volt-free)
USB (for backup/restore and label upload), remote Control Videojet 9560 via a web browser

Communications protocols

Compatible with Videojet CLARISUITE™
Videojet binary and simple-ASCII protocols
Compatible with any label design software which supports Zebra or Sato print engines
Zebra (ZPL), Sato (SBPL) and Markem-Imaje (Cimcomms) protocol support
EtherNet/IP™
PROFINET®

Interface

CLARITY™ Controller with interactive on-board video tutorials

Language capabilities

Arabic, Bulgarian, Czech, Danish, English, German, Greek, Finnish, French, Hebrew, Hungarian, Italian, Japanese, Korean, Dutch, Norwegian, Polish, Portuguese, Romanian, Russian, Serbian, simplified Chinese, Slovak, Spanish, Swedish, Thai, Turkish, Traditional Chinese, Vietnamese

Compressed air

6 Bar. 90psi, uncontaminated

Power consumption

90-260VAC (115W at 50 packs per minute)

Operating environment

Temperature Range: 41-104°F (5-40°C)
Humidity: 20-85% Relative, non-condensing

Weight

105.8lbs (48kg) (max., excluding ribbon and labels)

Applicable certifications

CE, TÜV

Dimensions

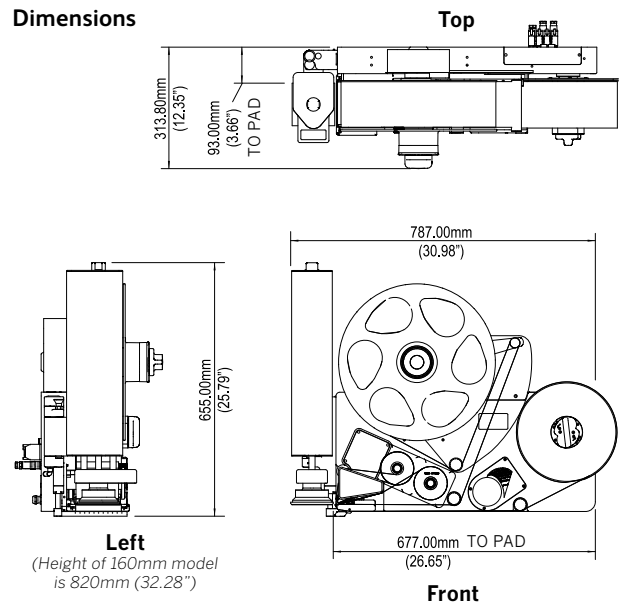

Call **+254-20-3893800**

Email **marketing.kenya@videojet.com**

or visit **www.videojet.co.ke**

Videojet Technologies
Keystone Park, Block A,
5 Riverside Drive, Westlands,
Nairobi, Kenya.

© 2024 Videojet Technologies Inc. — All rights reserved.

Videojet Technologies Inc.'s policy is one of continued product improvement. We reserve the right to alter design and/or specifications without notice. TrueType is a registered trademark of Apple Computer, Inc.

Part No. SL000734
ss-9560-tamp-en-ke-0724

