



Laser Marking System

# Videojet® 3210

Modernize your production with the Videojet 3210 CO<sub>2</sub> laser, engineered to bring laser marking within reach.

The Videojet 3210 30-Watt CO<sub>2</sub> laser marking system removes the need to compromise on quality versus cost. Advanced engineering and extensive laser application expertise are combined to deliver a refined design that makes laser coding achievable for everyone.

Whether new to laser coding or upgrading from an older system, the 3210 is designed to make the transition seamless with a compact, single-box solution that is easy to install and requires minimal operator training.



## Designed for efficiency

- A compact, lightweight design makes line integration seamless while versatile mounting configurations simplify line changeovers
- Videojet technicians are on hand to help ensure your laser is set up quickly and correctly
- The intuitive touchscreen interface and setup wizards make job creation straightforward

## A better solution for your line

- Precise and permanent laser codes are easily readable and help convey the quality of your products while providing built-in counterfeit protection
- Laser systems require no consumables so you never have to stock ink and solvent again
- An air-cooled laser source with 50,000 hours of expected life provides extended printer availability with minimal required service

# Videojet® 3210

## Laser Marking System

### Marking speed

Up to 1,300 characters/sec. (maximum marking speed is application dependent)

### Line speed

Up to 360 m/min. (1,181ft/min.) (maximum line speed is application dependent)

### Marking window

36x57 mm<sup>2</sup> to 72x115 mm<sup>2</sup>

### Wavelengths

9.3 μm, 10.2 μm, 10.6 μm

### Marking formats

Standard industrial fonts (Type 1 Windows® TrueType®) and Single line fonts  
Machine readable codes (OCR, 2D-matrix, etc.)  
Bar codes: BC25, BC251, BC39, BC128, GS1-128, EAN13, UPC\_A, RSS14, RSS14 Truncated, RSS14 Stacked, RSS14 Stacked Omnidirectional, RSS Limited, RSS Expanded, etc.  
Graphics, logos, symbols, etc.  
Linear, circular, angular, reverse, rotate  
Sequential and batch numbering  
Automatic date, layer and time coding; real-time clock  
Dot mode enables marking 2D codes faster than traditional grid mode

### Laser tube

Sealed CO<sub>2</sub> laser, power class 30-Watt

### Beam deflection

Steered beam with digital high-speed galvanometer scanners

### Focusing

Focal lengths: 100 / 150 / 200 mm (3.94 / 5.91 / 7.87 inches)

### Operator interface options

Handheld or touchscreen controller  
TCS+ via Web Browser

### Language capabilities

Arabic, Brazilian Portuguese, English, Japanese, Korean, Simplified Chinese, Spanish, Thai, Traditional Chinese, UK English, Vietnamese; interface dependent.

### Communication

Ethernet, TCP/IP  
Inputs for encoders and product detectors  
9 inputs / 5 outputs in addition to machine/operator interlocks

### Integration

Direct integration into complex production lines via scripting interface

### Electrical requirements

100-120 VAC; 200-240 VAC 0.7 KW

### Cooling system

Air cooled

### Environment

Temperature 40-105° F (5-40° C)  
Humidity 20% - 90%, non condensing

### Sealing and safety standards

IP54  
IEC 60825-1  
IEC 62368-1  
IEC 60204-1

### Approximate weight

41.9lbs. (19kg)

### Applicable certifications

CE  
Compliance (no certification required): ROHS

### Dimensions

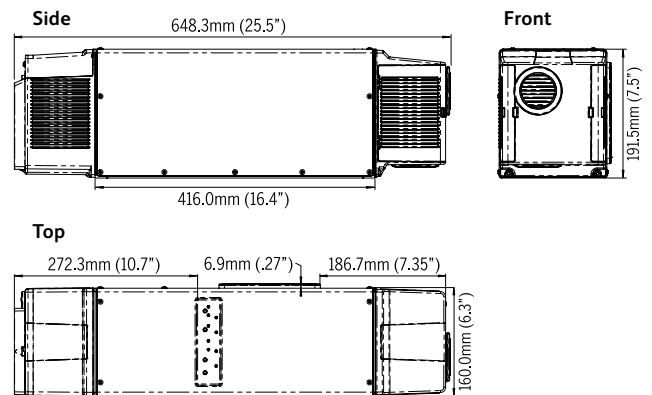

#### INVISIBLE LASER RADIATION

AVOID EYE OR SKIN EXPOSURE  
TO DIRECT OR SCATTERED RADIATION

MAX. AVERAGE POWER: 100 W  
WAVELENGTH: λ = 9-11 μm  
LASER CLASS 4  
(IEC 60825-1:2014)

Call +254-20-3893800

Email [marketing.kenya@videojet.com](mailto:marketing.kenya@videojet.com)

or visit [www.videojet.co.ke](http://www.videojet.co.ke)

Videojet Technologies  
Keystone Park, Block A,  
5 Riverside Drive, Westlands,  
Nairobi, Kenya

© 2021 Videojet Technologies Inc. — All rights reserved.

Videojet Technologies Inc.'s policy is one of continued product improvement. We reserve the right to alter design and/or specifications without notice. Windows is a registered trademark of Microsoft Corporation. TrueType is a registered trademark of Apple Inc., registered in the United States and other countries.

Part No. SL000699  
ss-3210-en-ken-1221

 **VIDEOJET®**