



Pallet labeling,
redefined



Print & Apply Labeling

Videojet 9560 PL

Reliable, automated pallet labeling that reduces
warehouse costs and mistakes



What's your biggest pallet labeling challenge?

The final step in your production process is just the beginning. There are many things that can go wrong with pallet labeling that delay shipping and cost your business.



The Videojet 9560 PL is a fully automated pallet labeling system specifically engineered to function in demanding conditions. Capable of covering two or three sides and up to four labels, it can process up to 120 pallets per hour across diverse applications. The system verifies label accuracy and reprints incorrect labels as needed, to help ensure error-free operations. The 9560 PL also facilitates secure warehouse management and adherence to industry regulations.

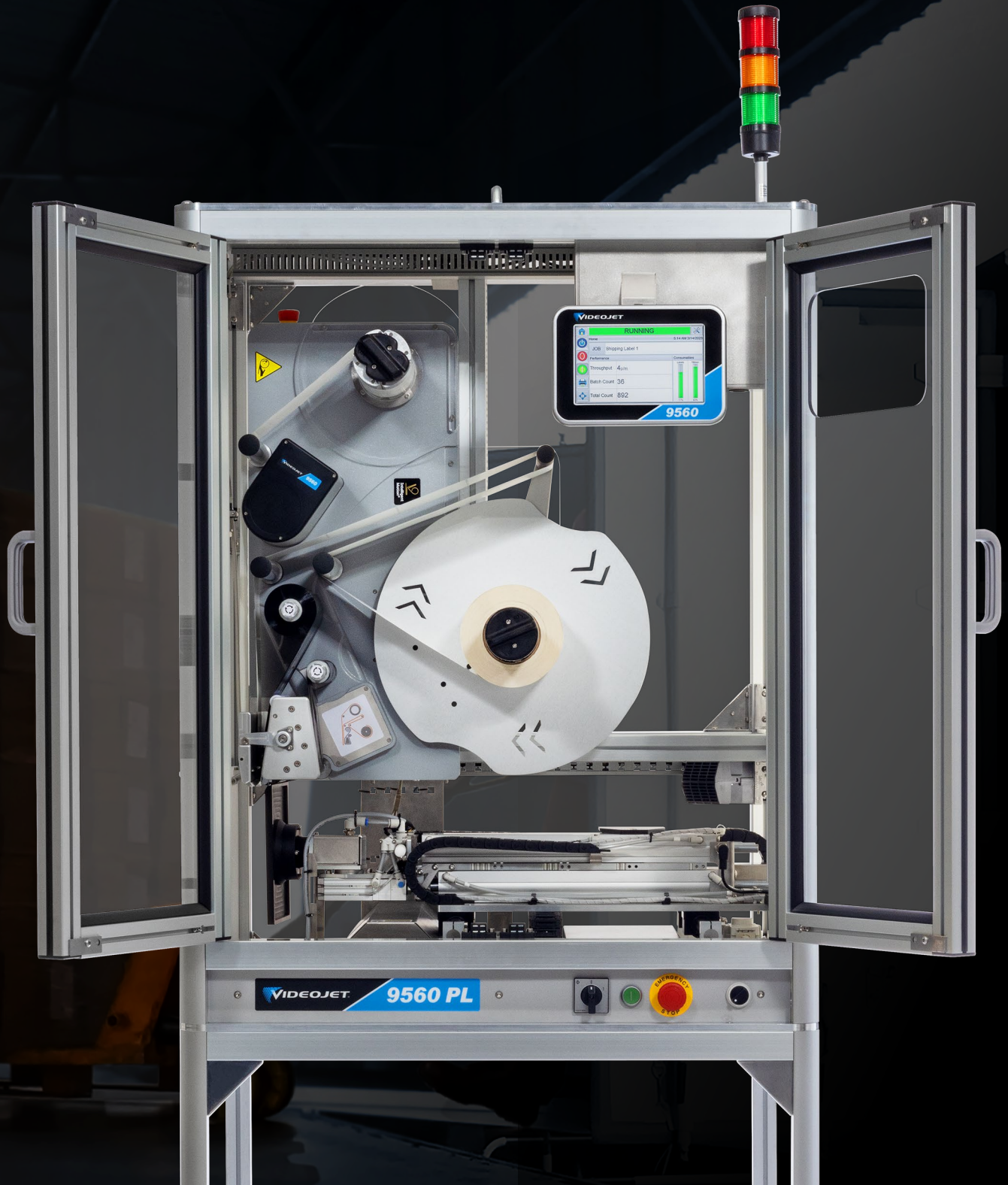

Pallet labeling to suit your application

Discover how the 9560 PL can benefit your business



Firm label adhesion on three sides of the pallet

The 9560 PL helps you avoid logistic hold-ups, with accurate and reliable label application. The tamp pad with wrist joint provides firm label adhesion – including on uneven surfaces – of up to four labels per pallet. The pad is fixed to a tamp arm with 700mm reach and 90-degree pivot, allowing label placement on up to three sides (front, side, rear) of the pallet.

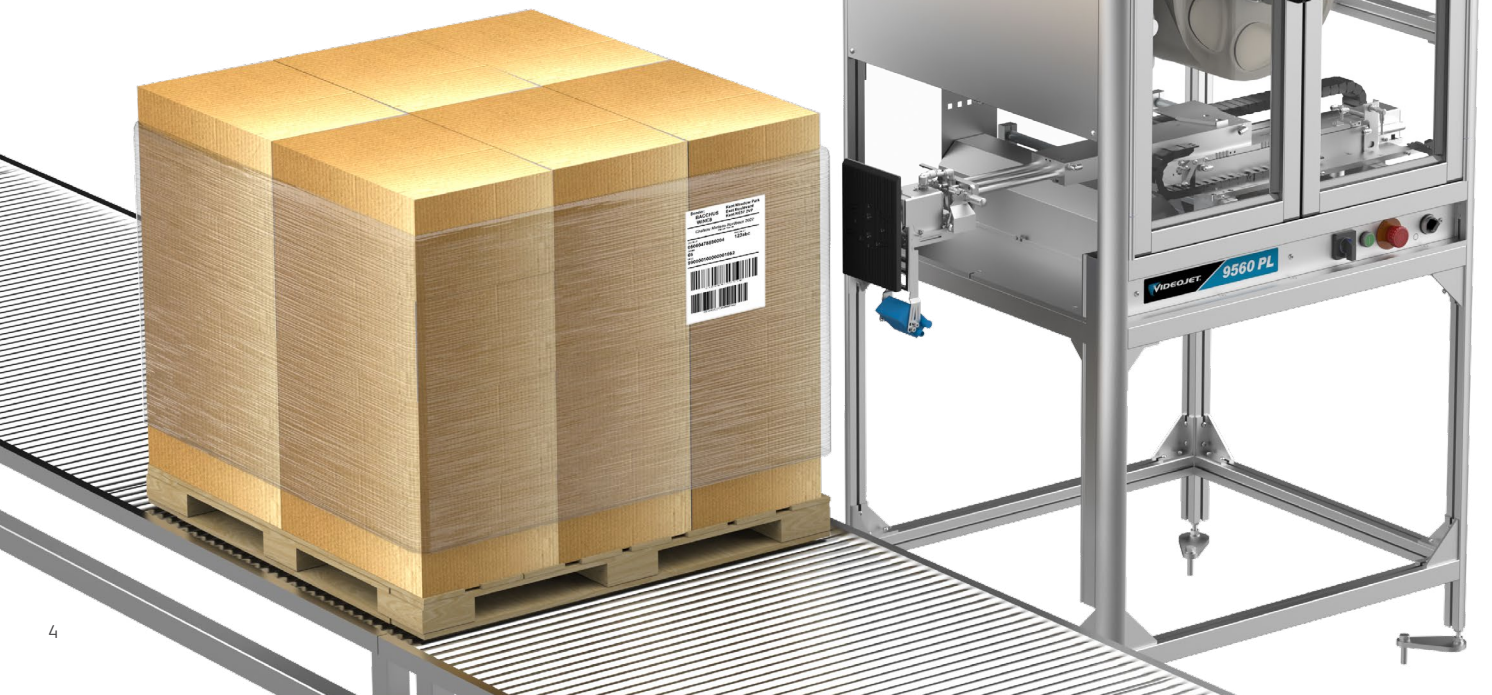



Easy user interface and integration

Many pallet labeling systems use multiple interfaces, which can cause confusion. The 9560 PL offers a single Graphical User Interface (GUI), minimizing errors and aiding with troubleshooting. On-board videos also help to simplify staff training. Options for a second GUI can assist with operation in guarded areas where safety comes first, with the ability to remotely operate the 9560 PL without having to enter restricted or gated areas.



Maximized label life

Labels exposed to harsh production environments can warp and deform, causing weak adhesion to the pallet, and unnecessary waste of label rolls. With its fully enclosed cabinet, the 9560 PL protects labels from harsh environmental conditions, including cold, humidity, wind, and dust.



Print GS1 compliant labels

The 9560 PL meets GS1 specifications by applying identical 6 x 4-inch (A6) or 6 x 8-inch (A5) labels on up to three sides. As per GS1, bar code labels are attached between 400mm (16in) and 800mm (31.5in) from the base of the pallet and are applied at least 50mm (2in) from all edges to avoid damage.

Rugged meets refined design

- 1 Fully enclosed cabinet**
Shutter for dust protection and optional heater for temperature control.
- 2 Labeling arm**
Extends up to 700mm beyond the enclosure.
- 3 Label applicator**
Labeling head swivels 90° in both directions for front or rear label placement.
- 4 Rotating tamp pad**
Automated solution in case of non-readable bar code helps to reduce downtime and reprint labels in landscape orientation.
- 5 Bar code scanner**
Integrated bar code scanner checks for label errors, ensures readability, and validates codes.
- 6 Safe operations**
Opening enclosure doors disable all moving assemblies, allowing users to safely service the system.
- 7 Born Digital connectivity**
Wi-Fi, Programmable Factory I/O, Ethernet/IP, and PROFINET come as standard for easy integration.

Industry-low footprint

You can put the 9560 PL almost anywhere. It only measures 900mm x 800mm, making it one of the most compact print-and-apply solutions on the market. So it's easier to fit close to the end of your shipping process. We also offer a range of variants to cater to your needs, including a choice of right or left-hand cabinet doors. So you can get a pallet labeler that works with your floor space.

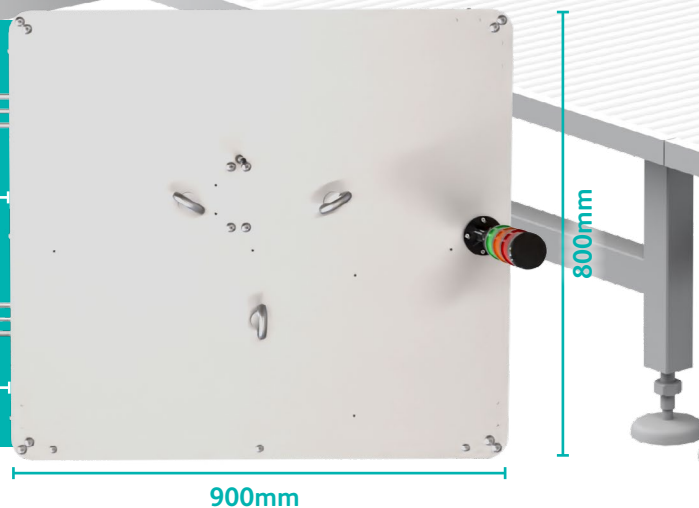
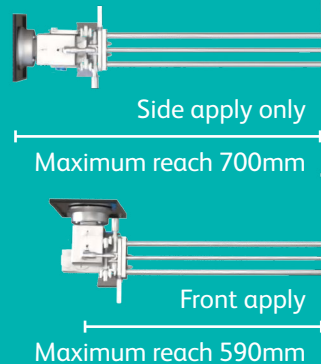

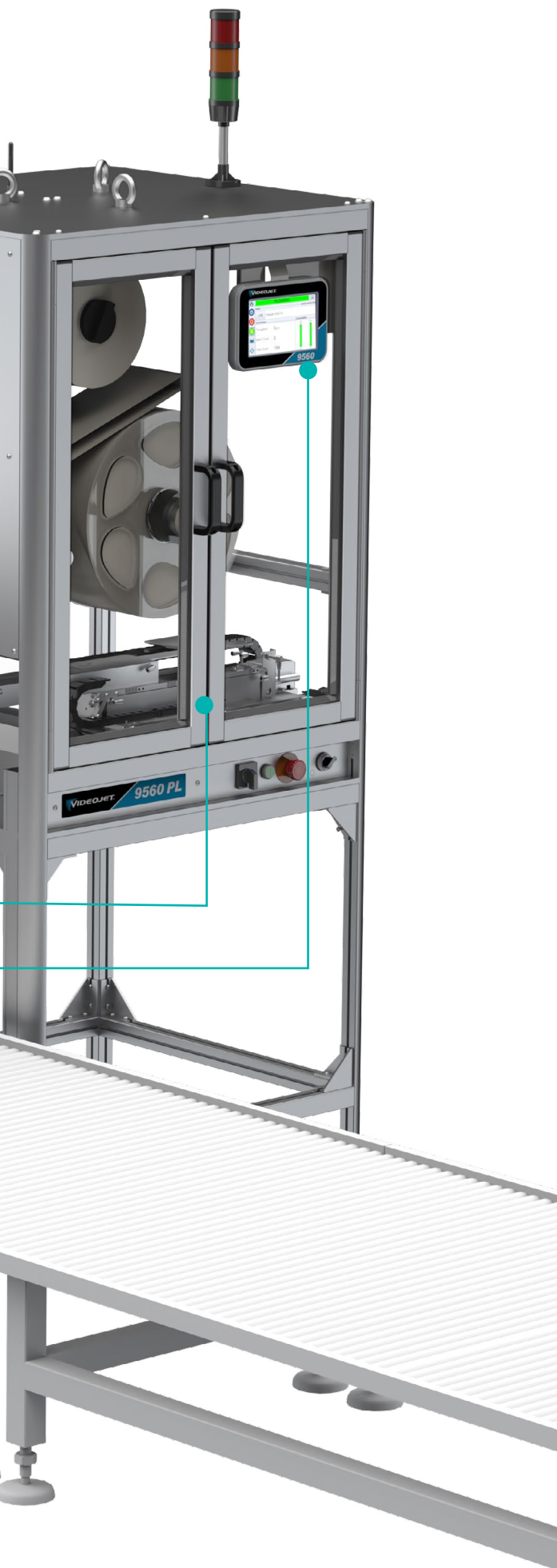

Reach new heights

Depending on your requirements, you can choose from three stand heights: H1, H2, or H3.

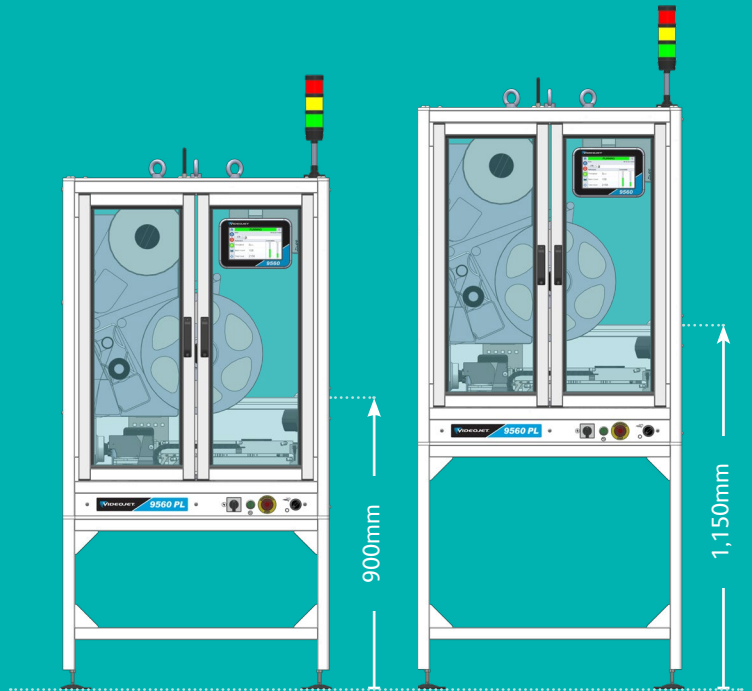

H1

H2

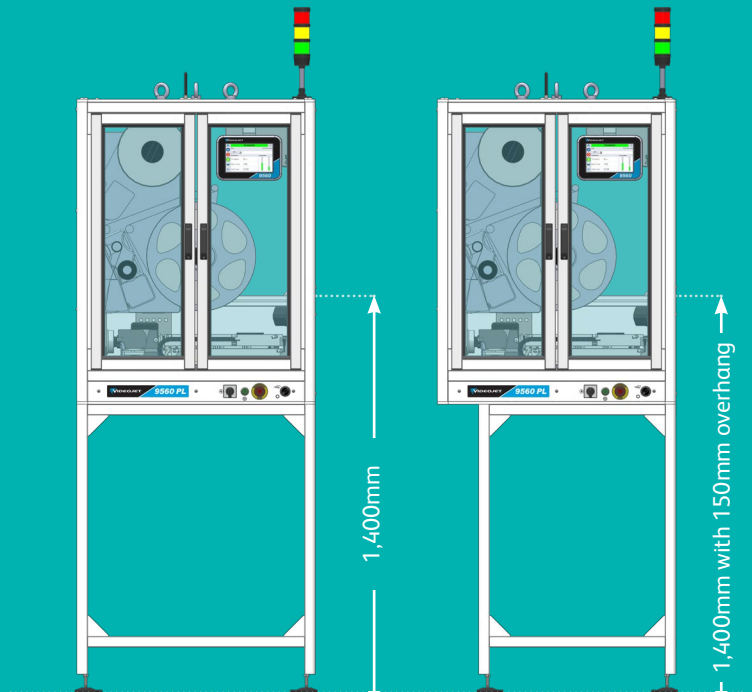

H3

H3 with overhang

The tamp also has a max reach of up to 700mm (trap door to the side of pallet) or 590mm (trap door to front face), with the overhang option of 150mm.

The next level in reliable pallet labeling solutions

Prevent manual rework

With its advanced rotating tamp pad, the 9560 PL automatically corrects no-read labels caused by dead dots. This reduces errors and downtime. By re-printing the label for the landscape orientation application, you can help ensure the bar code is readable and accurate, improving productivity and profitability.



Simplify your printer maintenance

Intelligent Motion technology enables all the design elements of the machine to be controlled with precision, simply removing the parts and adjustments that make most other labeling machines fail. It automatically deals with common issues such as manual adjustments, slipping clutch, and nip rollers, while the simplified design of the 9560 PL means that label and ribbon replacements can be performed quickly, helping to avoid downtime and lowering the cost of operation.



You can precisely and automatically control with **Intelligent Motion** clutchless, adjustment-free technology.

You can reduce operator errors with the **CLARiTY™** interface and built-in Code Assurance software.

Speed up label changeovers with a collapsible mandrel.

Integrate proven thermal transfer overprint technology with the print engine.

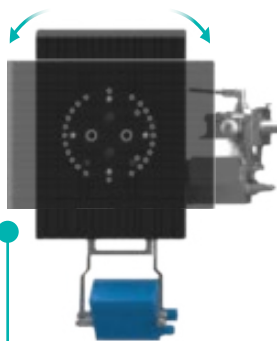

The arm applicator can also rotate 90 degrees to switch from portrait to landscape. This also extends the useful life of the printhead.

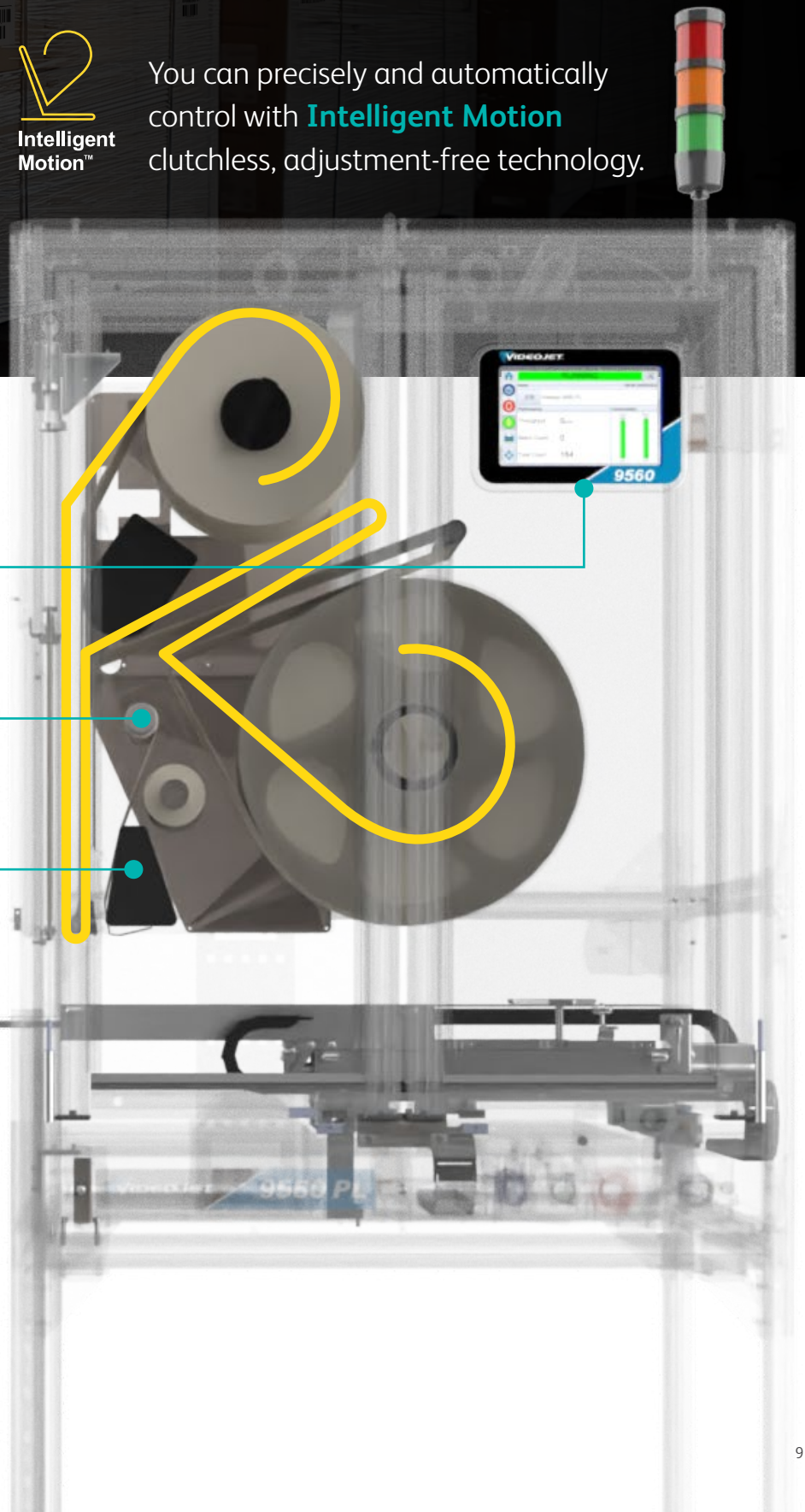

Easy installation across your plant systems



Anticipate technical issues and recover faster with on-demand support



First-to-know



First-to-react

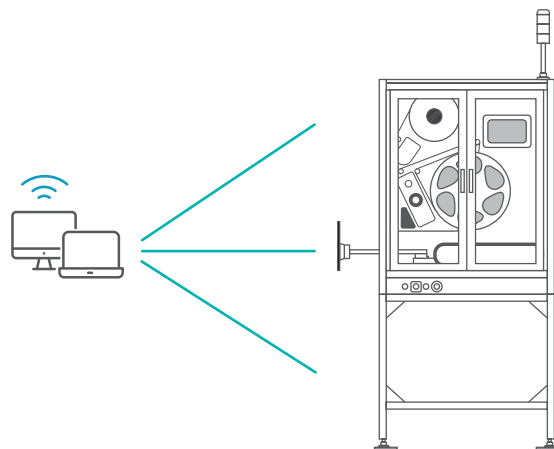

Real-time remote visibility

VideojetConnect™ Remote Service* provides real-time information on printer issues, allowing both Videojet experts and your technicians to monitor equipment status, troubleshoot issues, and improve long-term performance.

*Subject to availability in your country

Remote interface control

Web server capability allows customers to access the 9560 PL via supported web browsers on host computers. Up to five web server sessions are allowed for each printer.



Connectivity Ready



Designed for seamless integration into production and warehouse management systems, the 9560 PL's intelligent I/O capabilities include EtherNet/IP™, PROFINET®, Zebra and SATO protocols. VideojetConnect software solutions help ensure data integrity, central code management, and easy printer connection across the entire plant, with the industry-leading CLARiTY touch screen interface delivering intuitive job selection, code assurance and built-in productivity tools.

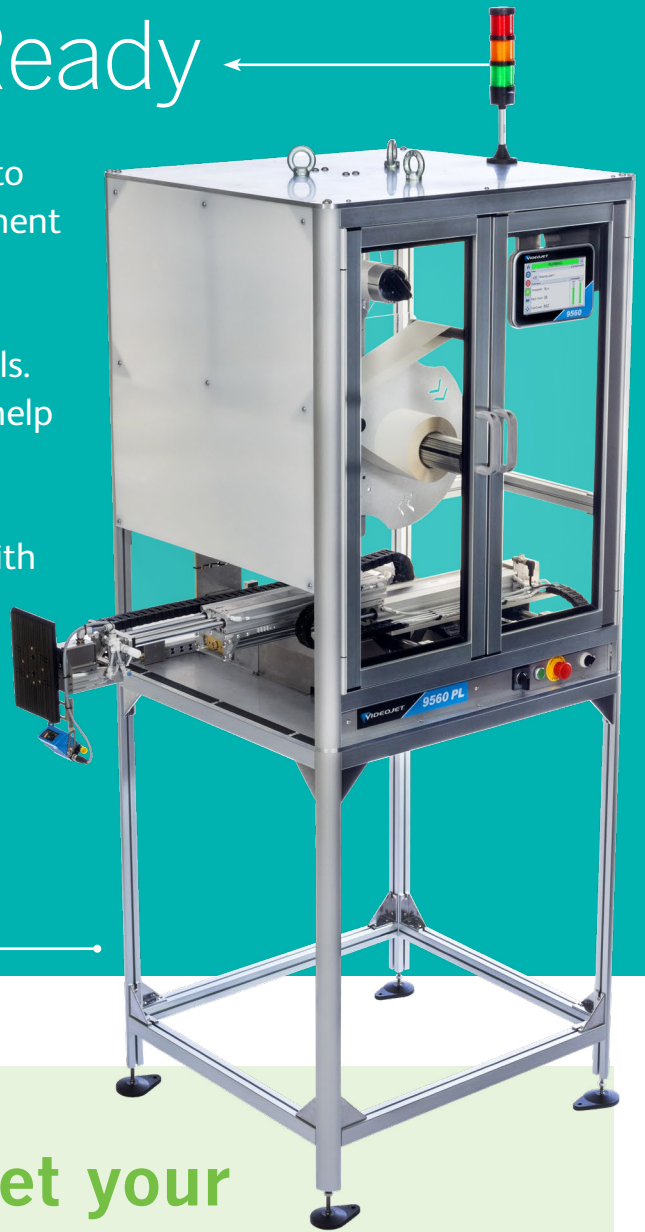

Technology to help meet your sustainability objectives

The Videojet labeling portfolio delivers the agility to stay ahead of constantly evolving **regulatory and sustainability requirements** and the resulting supply chain needs for waste reduction, recycling, and optimization of transportation resources.

Our labeling portfolio provides a range of sustainable labeling options – including eco-friendly materials, digital labeling, and optimized label placement – combined with our **deep expertise and unique integration solutions** can help you meet those requirements.

Our Intelligent Motion technology eliminates manual adjustments, increasing **the overall equipment effectiveness** of your line.

The Videojet pallet labeler features enable label application during printing, eliminating traditional failure points, and **drastically reducing line waste** from downtime.

With our comprehensive labeling solutions, you can reduce your **environmental impact and optimize your supply chain** while maintaining the highest levels of efficiency and reliability.



Peace of mind comes as standard

Videojet Technologies is a world-leader in the product identification market, providing in-line printing, coding, and marking products, application specific fluids, and product life cycle services.

Our goal is to partner with our customers in the consumer packaged goods, pharmaceutical, and industrial goods industries to improve their productivity, to protect and grow their brands, and to stay ahead of industry trends and regulations. With our customer application experts and technology leadership in Continuous Inkjet (CIJ), Thermal Inkjet (TIJ), Laser Marking, Thermal Transfer Overprinting (TTO), case coding and labeling, and wide array printing, Videojet has more than 400,000 printers installed worldwide.

Our customers rely on Videojet products to print on over ten billion products daily. Customer sales, application, service and training support is provided by direct operations with over 4,000 team members in 26 countries worldwide. In addition, Videojet's distribution network includes more than 400 distributors and OEMs, serving 135 countries.

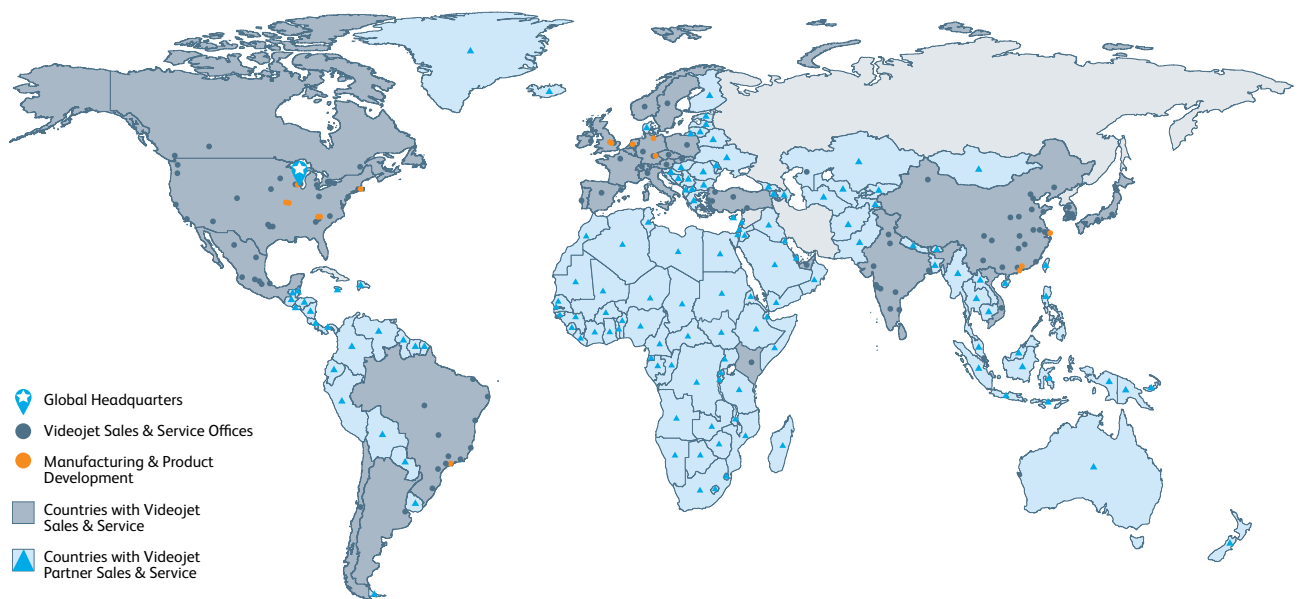

Call **+254-20-3893800**
Email **marketing.kenya@videojet.com**
or visit **www.videojet.co.ke**

Videojet Technologies
Keystone Park, Block A,
5 Riverside Drive, Westlands,
Nairobi, Kenya.

© 2023 Videojet Technologies Inc. — All rights reserved.
Videojet Technologies Inc.'s policy is one of continued product improvement.
We reserve the right to alter design and/or specifications without notice.

Part No. SL000723
br-9560-pl-en-ke-1123

